

# FENIX 200 SERIES

Rockwell | Brinell Hardness Testers

MANUAL & SEMI-AUTOMATIC



# FENIX 200AR

## Fast & affordable Rockwell testing...

Quality long life mechanics, readings from a precision analogue indicator. Load applied from a dead weight force actuator, with solid test load selector design. The newly designed C frame made out of steel (no casting) provides 100% more rigidity compared to traditional casted designs and assures excellent results, even after years of use.

The internal system can be easily serviced by removing the side and top covers, no need to turn the machine around.



## HARDNESS SCALES



**ROCKWELL** 10kgf – 150kgf



## ROCKWELL FORCE RANGE

1kgf	10kgf	FENIX 200 AR	150kgf	187.5kgf
------	-------	--------------	--------	----------

## HIGHLIGHTS

- 1 Rockwell scales : A | B | C | D | E | F | G | H | K | L | M | P | R | S | V
- 2 Test loads, pre-load : 10kgf, main-load : 60 | 100 | 150kgf
- 3 Adjustable hydraulic force speed damper
- 4 Adjustable dial indicator with 0.5 HR Rockwell units
- 5 Throat depth : 150mm
- 6 Working height : 260mm
- 7 Rockwell EN-ISO 6508, ASTM E-18
- 8 Machine weight (net) : 122kg
- 9 Machine dimensions : H765mm / W270mm / D555mm

# FENIX 200ACL

## Affordable Rockwell testing, re-invented...

A load cell, closed loop, force feedback, test force application system that is absolutely unique in this class of instruments. Limited mechanical structure, without weights or weight selection. Hardness scales can be selected on the digital display. Conduct Rockwell hardness testing with great force precision and without the disadvantage of a relative complex mechanical dead weight system.

The internal system can be serviced by removing the side and top covers, no need to turn the machine around.



### HARDNESS SCALES



**ROCKWELL** 10kgf – 150kgf



**BRINELL** 10kgf – 187.5kgf

#### TECHNOLOGY OF TODAY

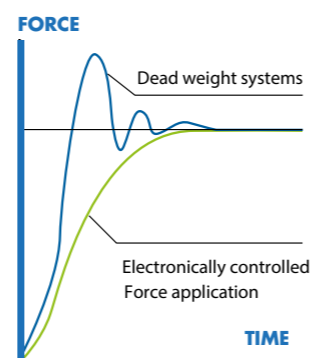

Load cell, closed loop, force feedback system

### ROCKWELL & BRINELL FORCE RANGE

1kgf	10kgf	FENIX 200 ACL	187.5kgf
------	-------	---------------	----------

## HIGHLIGHTS

- 1 Load cell, closed loop, force feedback, force application system, error <0,25%
- 2 Rockwell scales : A | B | C | D | E | F | G | H | K | L | M | P | R | S | V  
Brinell scales : HBW1/10 | HBW1/30 | HBW2.5/31.25 | HBW2.5/62.5 | HBW2.5/187.5  
HBW5/25 | HBW5/62.5 | HBW5/125 | HBW5/187.5 | HBW10/100
- 3 Digital display for scale indication, dwell time count down.
- 4 Start/stop & menu selection buttons.
- 5 Adjustable dial indicator with 0.5 HR Rockwell units
- 6 Throat depth : 150mm
- 7 Working height : 260mm
- 8 Machine weight (net) : 104kg.
- 9 Machine dimensions : H765mm/W270mm/D555mm

# SENSIBLE

# INNOVATION



**200 ACL**  
Multi loadcell,  
ball bearing,  
force actuator



**STANDARD**  
Force  
adjustable  
workpiece clamp

## Observe, Think, Try, Change...

Unparalleled in this class of Rockwell hardness testing machines is the electronic Load cell, closed loop, force feedback, force application system. Absolute maintenance free, automatic setting of test forces by choosing the Rockwell hardness scale. Error free operation, due to an automatic test cycle, applying the main load and correct pre-set dwell time.



# VARIOUS POSSIBILITIES

The FENIX 200 is larger than most other machines in its class. With a throat depth of 150mm and maximum workpiece height of 240mm, it offers the user a generous workspace. Moreover the FENIX 200 is super rigid, sturdy and can withstand the harshest environments. Compare these parameters with alternative products and find that FENIX is leading in its class.

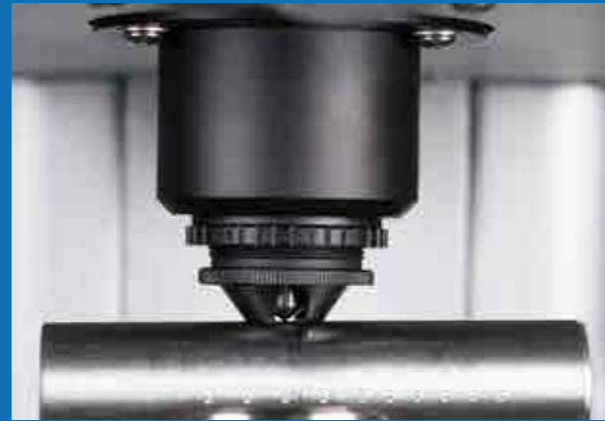

## INDENTER COVER & CLAMP

The FENIX 200 series is standard equipped with an indenter protection cover that includes an integrated spring loaded workpiece clamp pressing the workpiece firmly on the anvil and eliminating possible workpiece and spindle hysteresis. Adjustable clamp force, to avoid impressions on softer materials.

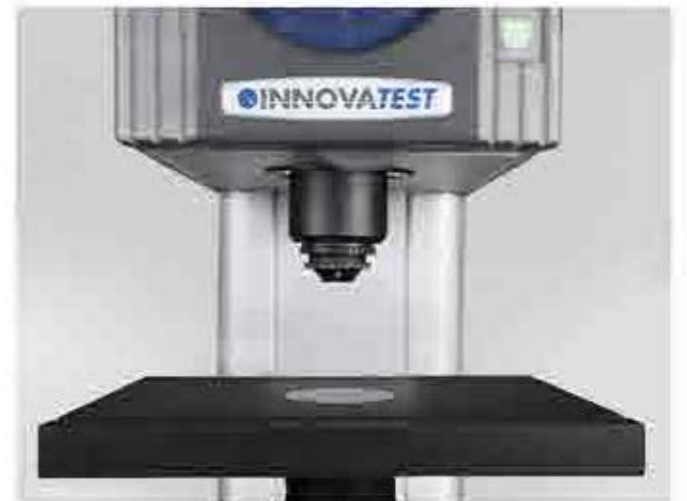



# SUPPORT YOUR BEST TESTING RESULTS

With our rigid designed Bench stands

- Rock solid bench stands
- 100% retractable drawer, bearing guidance, max 100kg load. Rubber anti slip bottom
- Lockable cabinet, 300mm high
- Adjustable feet, (+/- 50mm height adjustable to reach ergonomic working position)
- Made of corrosion resistant zinc plated steel with RAL powder coating
- Carrying capacity of 400kg
- Top surface made of 50mm Plywood with 1.5mm chemical resistant plastic plating, edges made of shock resistant 3mm ABS side liner
- Industrial quality, for workshop or laboratory

Designed for hardness testing instruments, painted in INNOVATEST® RAL colors matching our testers.



UN-STAND/960 71 x 75 x 80 cm



UN-STAND/965 150 x 75 x 80 cm

# ACCESSORIES

# FENIX 200

Schematic overview of the configuration options, standard and optional accessories

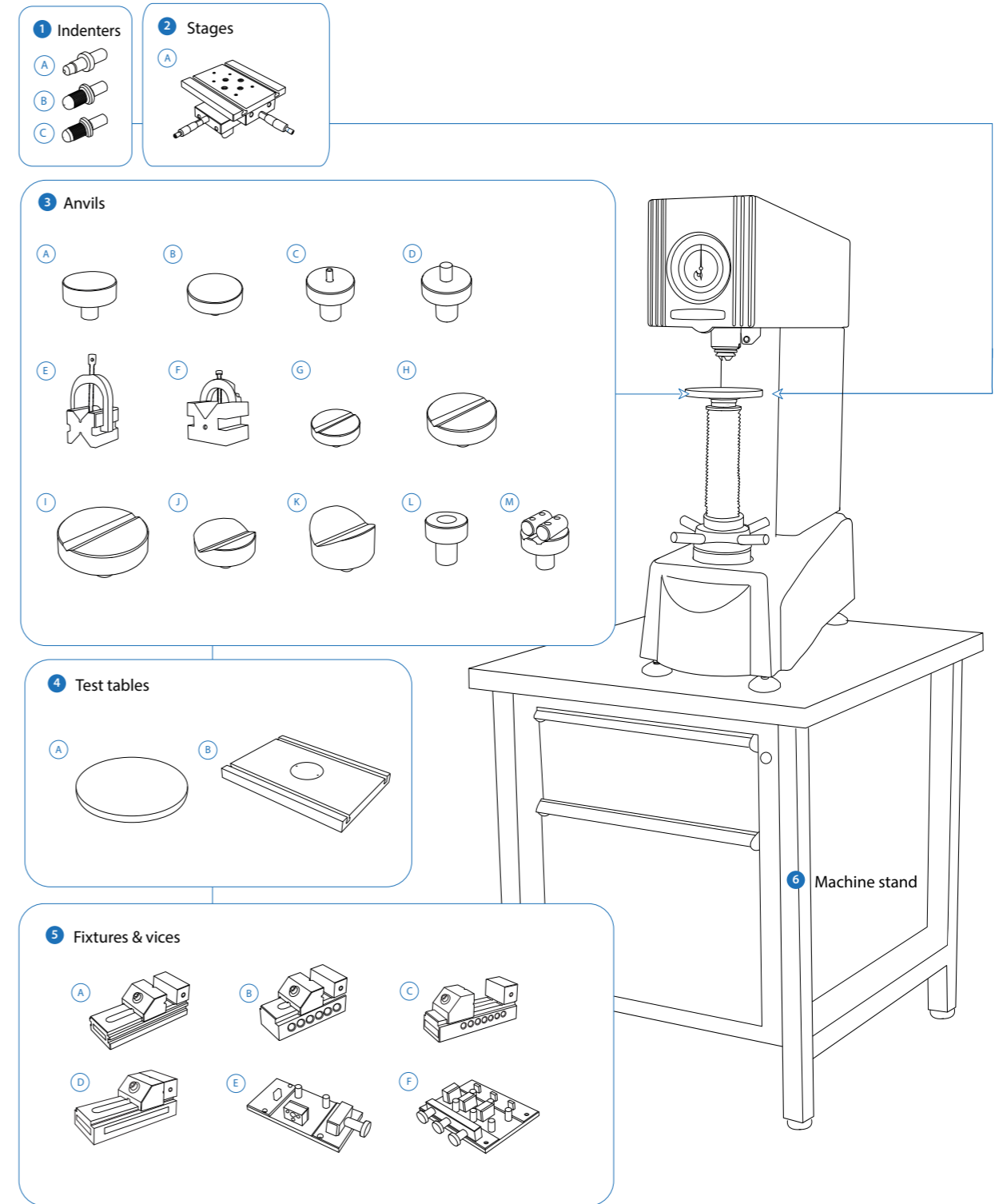

Not all accessories are displayed on this page. Full details can be found on the Order details page.

# ORDER DETAILS

## FENIX 200



Analogue, manual, Rockwell hardness tester 10kgf - 150kgf	FENIX 200AR	
Analogue, Load Cell Closed Loop, Rockwell hardness tester 10kgf - 187.5kgf	FENIX 200ACL	
Plug & Play prepared, calibration, sea & airworthy packing in "non coniferous wood" material	P&PSEAPACK60	

## ACCESSORIES

1	Indenters	A	Rockwell diamond indenter, ISO & ASTM certified	IN/6005	
		B	1mm Carbide Ball Indenter Ø6.35mm, ISO & ASTM certified	IN/7000	
			2.5mm Carbide Ball Indenter Ø6.35mm, ISO & ASTM certified	IN/7005	
			5mm Carbide Ball Indenter Ø6.35mm, ISO & ASTM certified	IN/7010	
			10mm Carbide Ball Indenter Ø6.35mm, ISO & ASTM certified	IN/7015	
		C	1/16" Carbide Ball Indenter, ISO & ASTM certified	IN/7506	
			1/8" Carbide Ball Indenter, ISO & ASTM certified	IN/7606	
			¼" Carbide Ball Indenter, ISO & ASTM certified	IN/7706	
			½" Carbide Ball Indenter, ISO & ASTM certified	IN/7806	
		2	Stages		Manual X-Y stage with analogue metric micrometers, 180x160mm Displacement: 25x25mm, scale 0.01mm, max load 300kg
	Lock flange			UN-XYZ BUSH42	
	Mounting plate for lock flange			UN-XYZ30FP40-42	
3	Anvils	A	Flat anvil 60mm	AS3000-19-04	
		B	Flat anvil 80mm	UN-TESTTABLE/002	
		C	Spot anvil 5mm	UN-ANVIL/010	
		D	Spot anvil 10mm	UN-ANVIL/011	
		E	V block with bracket 40x40x50mm (LxBxH)	UN-VBLOCK404050	
		F	Steel, cross type, (X) V-block 60x120x100mm 8-90mm pair	UN-CROSSBLOCK01	
		G	V-anvil ø40mm 6-60mm	UN-ANVIL/005	
		H	V-anvil ø63mm 6-60mm	UN-ANVIL/006	
		I	V-Anvil ø80mm 3.3-20mm	UN-ANVIL/040	
		J	V-Anvil ø80mm 12-80mm	UN-ANVIL/045	
		K	V-Anvil ø80mm 20-140mm	UN-ANVIL/050	
		L	Anvil for round specimen dia. 6-25,4mm	UN-ANVIL/200	
		M	Cylindrical V anvil 6-80mm	UN-CVANVIL680	
			Cylindrical V anvil 50-200mm	UN-CVANVIL50200	
			Test table 100x100mm, V groove 20mm wide, 10mm deep	UN-TESTTABLE/040	
4	Test Tables	A	Testing table flat ø180mm, screwfix	ASV700-00-20	
			Testing table flat ø235mm, screwfix	UN-TESTTABLE/014	
		B	Large flat surface testing table 350x250mm, thickness 30mm with 2 T-slots, for large components	UN-TESTTABLE/015	
			Lock flange	ASV700-21-01	

5	Fixtures and Vices	A	Polished precision vice with lock down system, jaw width 25mm, opens 20mm	UN-VICE/210	
		B	Polished precision vice with lock down system, jaw width 36mm, opens 42mm	UN-VICE/215	
		C	Polished precision vice with lock down system, jaw width 48mm, opens 75mm	UN-VICE/220	
		D	Polished precision vice with lock down system, jaw width 75mm, opens 100mm	UN-VICE/230	
		E	JOMINY Fixture, for 1 quench end test sample, quick release function	UN-JOMFIX1	
		F	JOMINY Fixture, for 3 quench end test sample, quick release function	UN-JOMFIX3	
6	Machine Stand		Cabinet test table with drawer for hardness testers 71x75x80cm	UN-STAND/960	
			Seaworthy packing box for 950/960	PACK/100	
			Direct and Indirect Verification/Calibration & BRINELL Certification in compliance with ISO & ASTM, NADCAP. Includes Direct force and depth verification report, machine hysteresis report, indirect verification report (block readings), GR & R report, flat fee for selected common scales, per scale	CALCEFRDW/1B	
			Direct and Indirect Verification/Calibration & ROCKWELL Certification in compliance with ISO & ASTM, NADCAP. Includes Direct force and depth verification report, machine hysteresis report, indirect verification report (block readings), GR & R report, flat fee for selected common scales, per scale	CALCEFRDW/1R	
	Cover		Anti Static machine cover 350x550x770mm	UN-COVER1	

# ACCESSORIES

## INDENTERS



## STAGES



## TEST TABLES



## ANVILS



## FIXTURES AND VICES



## MACHINE STANDS





# SPECIFICATIONS

## HARDNESS SCALES

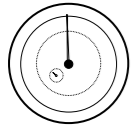
	<b>ROCKWELL</b> EN-ISO 6508, ASTM E-18 JIS Z 2245	A   B   C   D   E   F   G   H   K   L   M   P   R   S   V
	<b>BRINELL*</b> EN-ISO 6506, ASTM E92 JIS Z 2243	HBW1/30   HBW2.5/31.25   HBW2.5/62.5   HBW2.5/187.5   HBW5/25   HBW5/62.5   HBW5/125   HBW10/100 * FENIX 200ACL only

## TEST FORCE 200AR

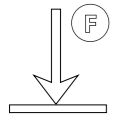
	<b>Force application</b>	Dead weight system via load selector
	<b>Test forces</b>	Preload : 10kgf, main loads : 60   100   150kgf
	<b>Force range</b>	FENIX 200AR 10kgf – 150kgf
	<b>Test force tolerance</b>	< 1% for test force 10kgf to 150kgf
	<b>Dwell time settings</b>	User defined

## TEST FORCE 200ACL

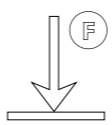
	<b>Force application</b>	Load cell, closed loop, force feedback system
	<b>Test forces</b>	Preload : 10kgf, main loads : 25   30   31.25   60   62.5   100   125   150   187.5kgf
	<b>Force range</b>	FENIX 200ACL 10kgf – 187.5kgf
	<b>Test force tolerance</b>	< 0.25% for test force 10kgf to 187.5kgf
	<b>Dwell time settings</b>	Default 10 seconds, user defined. Up to 999 seconds

## GENERAL

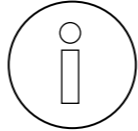
	<b>Machine dimension</b>	765mm x 270mm x 555mm
	<b>Machine weight</b>	FENIX 200ACL: 104kg      FENIX 200AR : 122kg
	<b>Power supply</b>	100VAC to 240VAC, 50/60Hz, single phase
	<b>Operating temperature</b>	10°C to 35°C, non-condensing
	<b>Power consumption</b>	10W
	<b>Humidity</b>	10% to 90%, non-condensing



# TECHNICAL DRAWINGS

All dimensions in these drawings are in mm, approximate. Working heights and or workpiece accommodation varies depending on the stages and stage accessories used.

Please contact our sales department for more details.

FENIX 200AR

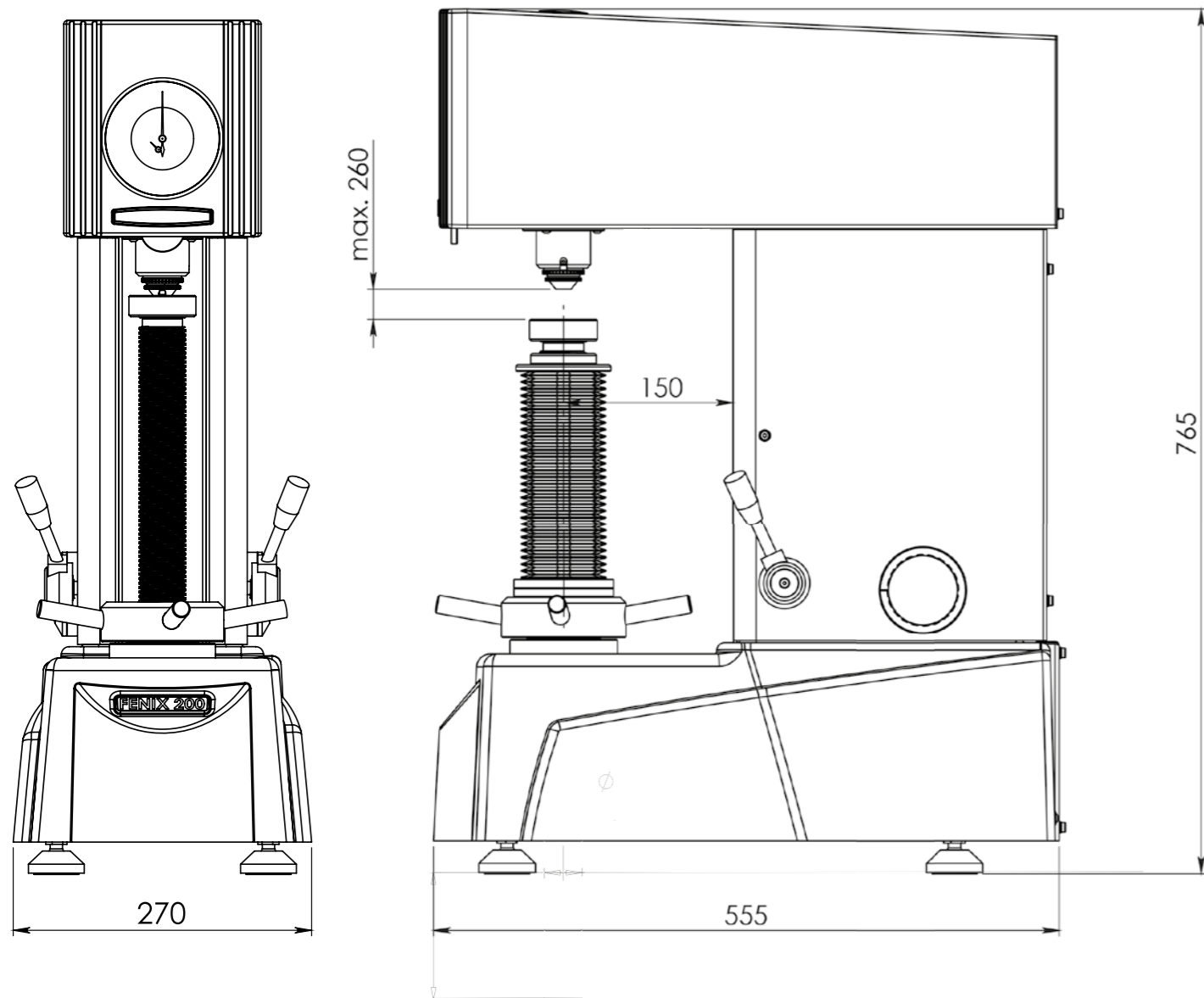

FENIX 200ACL

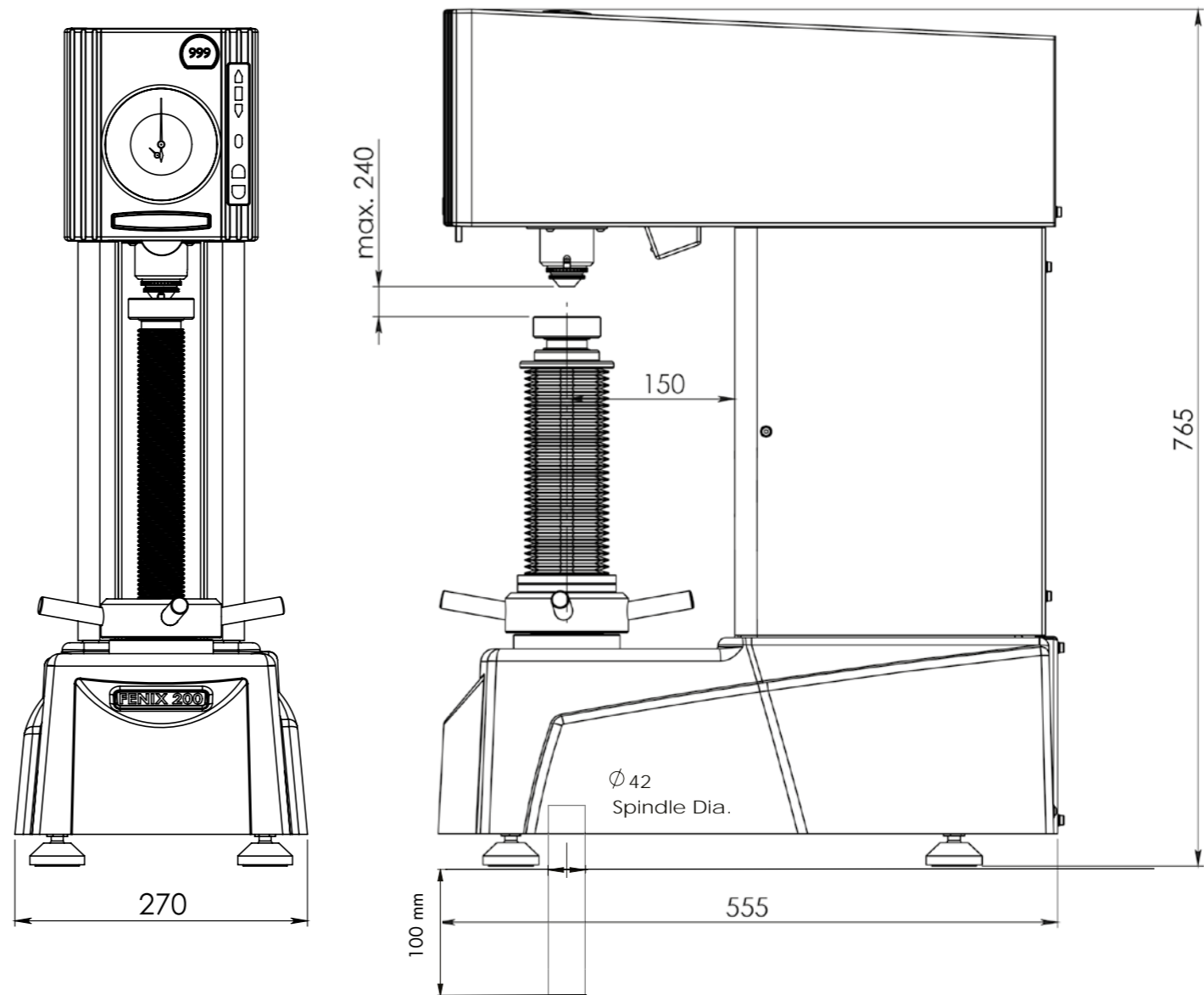



**FAST & AFFORDABLE  
ROCKWELL TESTING**

## OTHER MODELS IN THE ROCKWELL RANGE



### NEXUS 605

Load Cell, closed loop Rockwell/Superficial Rockwell/ Brinell hardness tester, with full color touch screen.  
*See brochure B18N605/XX*



### NEXUS 610

Load Cell, closed loop Rockwell/Superficial Rockwell/ Brinell hardness tester, with integrated PC, Windows 10, wifi etc. full color touch screen.  
*See brochure B18N610/XX*



### VERZUS 720

Load Cell, closed loop Rockwell/Super Rockwell/ Brinell hardness tester, with direct depth measuring system, integrated PC, Windows 10,wifi, full color touch screen.  
*See brochure B19V720/XX*



### NEMESIS 6100

Load Cell, Closed loop Fully automatic Rockwell/ Superficial Rockwell (Brinell) hardness tester with descending test head & fixed workpiece position. full color touch screen operation.  
*See brochure B19N6100/XX*



### NEMESIS 6200

Load Cell, Closed loop Fully automatic Rockwell/ Superficial Rockwell (Brinell) hardness tester with descending test head & fixed workpiece position, integrated PC, Windows 10, Wifi, full color 15 " industrial capacitive touch screen.

Includes CNC motorized X-Y stage, overview camera and advanced software (IMPRESSIONS) for automatic pattern testing and fixture recognition.  
*See brochure B19N6200/XX*



Changes in products and/or product specifications can emerge due to new technologies and continuous development.

We reserve the right to change or modify specifications of the products without prior notice. We recommend you to contact our sales office for up-to-date information.

Brochure B18F200/14/EN

© All rights reserved, 2018

Distributor :

## **CORPORATE HEAD OFFICE**

### **INNOVATEST Europe BV**

**Manufacturing, Distribution & Service**

Borgharenweg 140  
6222 AA MAASTRICHT  
The Netherlands

Phone: +31 43 3520060

Fax: +31 43 3631168

[info@innovatest-europe.com](mailto:info@innovatest-europe.com)

[www.innovatest-europe.com](http://www.innovatest-europe.com)

### **INNOVATEST Deutschland GmbH Sales & Service**

Phone: +49 245 670 59 500  
[info@innovatest-deutschland.com](mailto:info@innovatest-deutschland.com)  
[www.innovatest-deutschland.com](http://www.innovatest-deutschland.com)

### **INNOVATEST Polska sp. z.o.o Sales & Service**

Phone: +48 697 099 826  
[info@innovatest-polska.pl](mailto:info@innovatest-polska.pl)  
[www.innovatest-polska.pl](http://www.innovatest-polska.pl)

### **INNOVATEST Shanghai Co., Ltd. Sales & Service**

Phone: +86 21 60906200  
[info@innovatest-shanghai.com](mailto:info@innovatest-shanghai.com)  
[www.innovatest-shanghai.com](http://www.innovatest-shanghai.com)

### **INNOVATEST Japan Co., Ltd. Sales & Service**

Phone: +81 3 3527 3092  
[info@innovatest-japan.com](mailto:info@innovatest-japan.com)  
[www.innovatest-japan.com](http://www.innovatest-japan.com)

### **INNOVATEST USA Company Sales & Service**

Phone: +1 267 317 4300  
[info@innovatest-usa.com](mailto:info@innovatest-usa.com)  
[www.innovatest-usa.com](http://www.innovatest-usa.com)

### **INNOVATEST South East Asia Sales & Service**

Phone: +65 6451 1123  
[info@innovatest-singapore.com](mailto:info@innovatest-singapore.com)  
[www.innovatest-singapore.com](http://www.innovatest-singapore.com)