

# VERZUS 720 SERIES

Rockwell | Brinell Hardness Testers

**MANUAL & SEMI-AUTOMATIC**



# VERZUS 720

## Quality, durability, accuracy

The VERZUS 720RS(B) is constructed around a rock solid C-frame with supreme rigidity. The closed loop system based on a load cell and precision force actuator guarantees the best GR & R results. The test forces can range from 1kgf to 250kgf and a full test cycle can be as little as 13 seconds (at a dwell time of 10 seconds).

Due to the top quality ultra-precise HEIDENHAIN optical depth measurement system, 0.1 micron depth reading is a standard feature on the VERZUS 720. The optical sensor is positioned exactly on the axis of the indenter shaft. This construction eliminates possible fault readings due to tolerance or inaccuracies in the force actuator system.

A further great beneficial advantage of measuring the indenting depth in such an absolute direct way is that the tester can be easily verified, calibrated and if required adjusted in accordance with the applicable DIN EN ISO, ASTM and JIS standards.

For demanding users the VERZUS 720 can be equipped with a motorized spindle (optional) that lifts your work piece, without any effort, to the required testing position.

COMPLIANT TO ASTM, EN DIN ISO, JIS,  
WITH A DIRECT DEPTH-READING SYSTEM

## HARDNESS SCALES



**ROCKWELL** 3kgf – 150kgf



**BRINELL**  
(Optional) 1kgf – 250kgf

## ROCKWELL FORCE RANGE

1kgf    3kgf    **VERZUS 720RS**    150kgf    250kgf

## HIGHLIGHTS

- 1 Fully automatic, load cell, closed loop, force feedback system
- 2 Direct depth reading system
- 3 Optional BIOS camera for Brinell hardness testing
- 4 Clamp for indenter protection and workpiece fixation
- 5 Full color industrial 6.5" HD capacitive touch screen
- 6 Real feel rubber buttons for glove operation
- 7 IMPRESSIONS™ advanced workflow software
- 8 Adjustable workpiece illumination
- 9 Robust 1 piece steel C frame (no welding) spindle with bellows
- 10 High-quality ABS covers, avoids machine damage
- 11 Large workpiece accommodation: 315 mm (H) x 200 mm (D)



### TECHNOLOGY OF TODAY

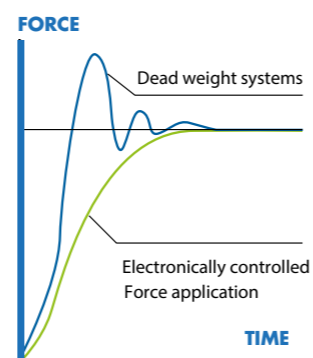

Load cell, closed loop,  
force feedback system



# SENSIBLE INNOVATION

## ADVANCED MACHINE CONSTRUCTION, ROBUST, SIMPLE OPERATION

VERZUS stands for versatile unparalleled rigidity. Unique in this class of Rockwell & Brinell hardness testing machines is the electronic Load cell, closed loop, force feedback and direct depth reading system.

## “Intuitive operation and workflow control..”

IMPRESSIONS™ is the ultra-modern user interface of all Innovatest hardness testing machines. It offers unparalleled simplicity in operation but yet, includes the most advanced functions found in hardness testing.

With only a minimum of operator skills required, IMPRESSIONS™ leads you through the set up process, in just seconds, not even minutes. Standard features, complex tasks and advanced work flow at your fingertips.

Typical examples are:

Scale setting, Test methods setting, Limits, Conversion to other hardness scales, Graphics, File saving, Test program saving, Zoom function etc. All standardized hardness testing methods have been programmed in the software and can be selected at any time.

# EXPERIENCE IMPRESSIONS LT

INNOVATIVE SOFTWARE FUNCTIONS

The 6.5" touch screen provides easy tester set up and general operation. The soft buttons on the front panel allow tester operation with gloves in a very dirty environment.



### 1 GIPE: GRAPHIC INDENT PROCESS EVALUATION



### 2 INDENT ZOOM MAGNIFICATION

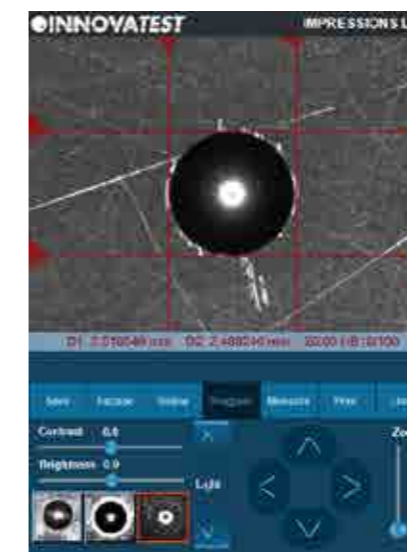

### 3 REPORT GENERATOR

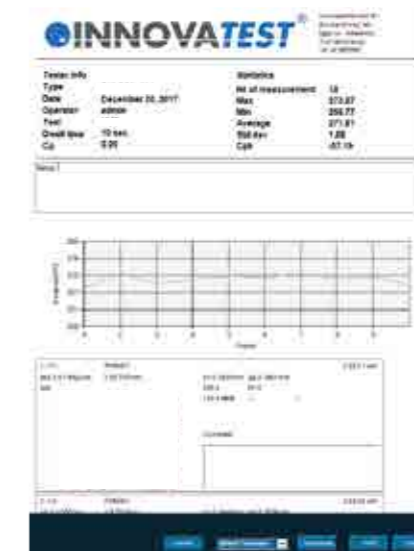

VARIOUS

# POSSIBILITIES

The VERZUS 720 Series is a workhorse in the range of Rockwell hardness testers. With a throat depth of 200mm and maximum workpiece height of 315mm, it offers the user a generous workspace. It is designed for 24/7 use and conducts testing at a high speed.

Advantage of measuring the indenting depth in an absolute direct way is the easy process of calibration required in accordance to DIN EN ISO, ASTM and JIS standards.



#### INDENTER COVER & CLAMP

The VERZUS 720 is standard equipped with an indenter protection cover that includes an integrated spring loaded workpiece clamp pressing the workpiece firmly on the anvil and eliminating possible workpiece and spindle hysteresis. Adjustable clamp force, to avoid impressions on softer materials.



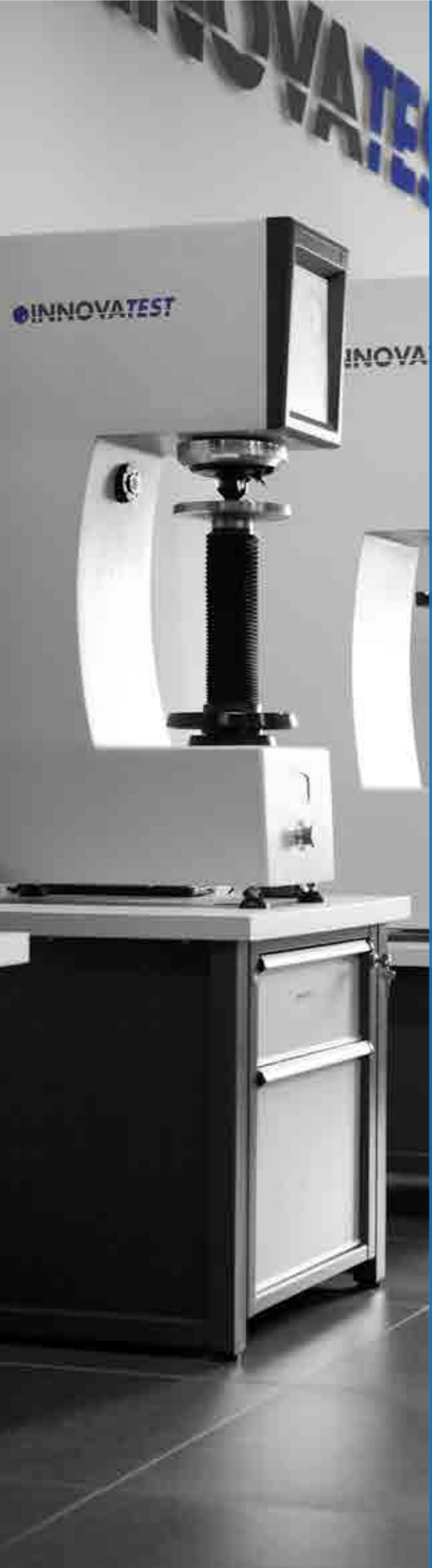

# SUPPORT YOUR BEST TESTING RESULTS

With our rigid designed Bench stands

- Rock solid bench stands
- 100% retractable drawer, bearing guidance, max 100kg load. Rubber anti slip bottom
- Lockable cabinet, 300mm high
- Adjustable feet, (+/- 50mm height adjustable to reach ergonomic working position)
- Made of corrosion resistant zinc plated steel with RAL powder coating
- Carrying capacity of 400kg
- Top surface made of 50mm Plywood with 1.5mm chemical resistant plastic plating, edges made of shock resistant 3mm ABS side liner
- Industrial quality, for workshop or laboratory

Designed for hardness testing instruments, painted in INNOVATEST® RAL colors matching our testers.



UN-STAND/960 71 x 75 x 80 cm



UN-STAND/965 150 x 75 x 80 cm

# ACCESSORIES

# VERZUS 720

Schematic overview of the configuration options, standard and optional accessories

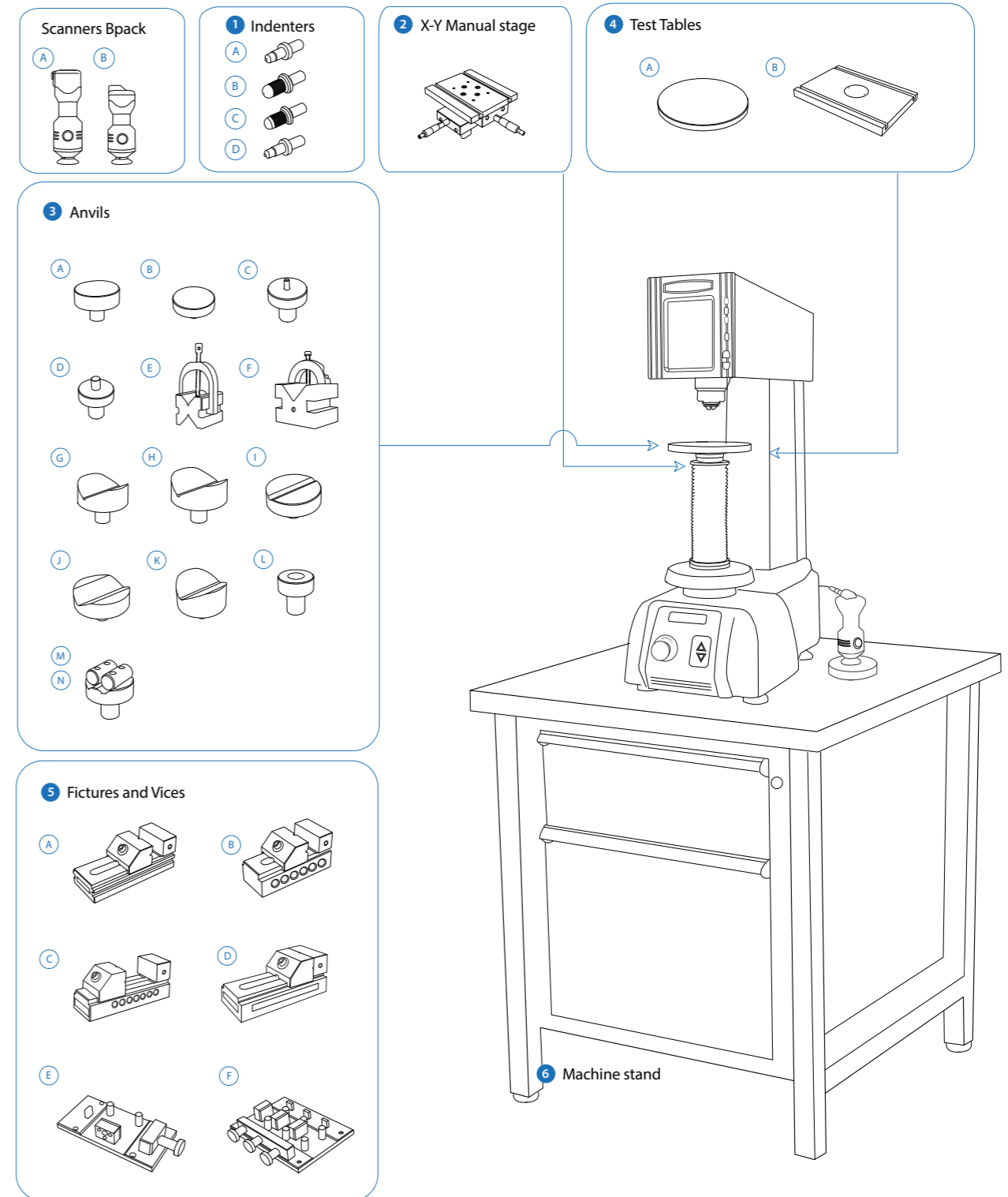

Not all accessories are displayed on this page. Full details can be found on the Order details page.

# ORDER DETAILS

## VERZUS 720



Rockwell Twin Scale hardness tester 3kgf - 150kgf, PC Integrated, IMPRESSIONS™	VERZUS 720RS
Plug & Play prepared, calibration, sea & airworthy packing in "non coniferous wood" material	P&PSEAPACK100
Motorized Z-Axis (optional)	VERZUS 700/010

## ACCESSORIES

1	Indenters	A	Rockwell C Diamond Indenter. Ø6.35mm. ISO & ASTM certified	IN/6005	
			B	Brinell Indenter 1mm. Includes 1 carbide ball. Ø6.35mm. ISO & ASTM certified	IN/7000
				Brinell Indenter 2.5mm. Includes 1 carbide ball. Ø6.35mm. ISO & ASTM certified	IN/7005
				Brinell Indenter 5mm. Includes 1 carbide ball. Ø6.35mm. ISO & ASTM certified	IN/7010
				Brinell Indenter 10mm. Includes 1 carbide ball. Ø6.35mm. ISO & ASTM certified	IN/7015
			C	Rockwell Ball Indenter 1/16". Includes 1 carbide ball. Ø6.35mm. ISO & ASTM certified	IN/7506
				Rockwell Ball Indenter 1/8". Includes 1 carbide ball. Ø6.35mm. ISO & ASTM certified	IN/7606
				Rockwell Ball Indenter 1/4". Includes 1 carbide ball. Ø3mm. ISO & ASTM certified	IN/7706
				Rockwell Ball Indenter 1/2". Includes 1 carbide ball. Ø3mm. ISO & ASTM certified	IN/7806
			D	Macro Vickers Indenter Ø6.35mm, ISO & ASTM certified	IN/8010
				1.0mm carbide ball, ISO & ASTM certified only for ø6.35mm	IN/2005
				2.5mm carbide ball, ISO & ASTM certified only for ø6.35mm	IN/2010
				5.0mm carbide ball, ISO & ASTM certified only for ø6.35mm	IN/2015
				10.0mm carbide ball, ISO & ASTM certified only for ø6.35mm	IN/2020
				1/16" carbide ball, ISO & ASTM certified	IN/2507
				1/8" carbide ball, ISO & ASTM certified	IN/2509
				1/4" carbide ball, ISO & ASTM certified	IN/2514
				1/2"carbide ball, ISO & ASTM certified	IN/2519
			2	X-Y Manual Stage	
	Lock flange	UN-XYZ BUSH42			
	Mounting plate for lock flange	UN-XYZ30FP40-42			
3	Anvils	A	Flat anvil 60mm	AS3000-19-04	
		B	Flat anvil 80mm	UN-TESTTABLE/002	
		C	Spot anvil 5mm	UN-ANVIL/010	
		D	Spot anvil 10mm	UN-ANVIL/011	
		E	V block with bracket 40x40x50mm (LxBxH)	UN-VBLOCK404050	
		F	Steel, cross type, (X) V-block 60x120x100mm 8-90mm pair	UN-CROSSBLOCK01	
		G	V-anvil ø40mm 6-60mm	UN-ANVIL/005	
		H	V-anvil ø63mm 10-100mm	UN-ANVIL/006	
		I	V-Anvil ø80mm 3.3-20mm	UN-ANVIL/040	
		J	V-Anvil ø80mm 15-80mm	UN-ANVIL/045	
		K	V-Anvil ø80mm 23-40mm	UN-ANVIL/050	
		L	Anvil for round specimen dia. 6-25,4mm	UN-ANVIL/200	

		M	Cylindrical V anvil 6-80mm	UN-CVANVIL680
		N	Cylindrical V anvil 50-200mm	UN-CVANVIL50200
4	Test Tables		Test table 100x100mm, V groove 20mm wide, 10mm deep	UN-TESTTABLE/040
		A	Testing table flat ø180mm, screwfix	ASV700-00-20
			Testing table flat ø235mm, screwfix	UN-TESTTABLE/014
		B	Large flat surface testing table 350x250mm, thickness 30mm with 2 T-slots, for large components	UN-TESTTABLE/015
			Large flat surface testing table 450x350mm, thickness 35mm with 2 T-slots, for large components	UN-TESTTABLE/016
	Clamping, Locking & Fixing adapters		Lock flange	ASV700-21-01
5	Fixtures and Vices	A	Polished precision vice with lock down system, jaw width 25mm, opens 20mm	UN-VICE/210
		B	Polished precision vice with lock down system, jaw width 36mm, opens 42mm	UN-VICE/215
		C	Polished precision vice with lock down system, jaw width 48mm, opens 75mm	UN-VICE/220
		D	Polished precision vice with lock down system, jaw width 75mm, opens 100mm	UN-VICE/230
		E	JOMINY Fixture, for 1 quench end test sample, quick release function	UN-JOMFIX1
		F	JOMINY Fixture, for 3 quench end test sample, quick release function	UN-JOMFIX3
6	Machine Stand		Cabinet test table with drawer for hardness testers 71x75x80cm	UN-STAND/960
			Cabinet test table with drawer for hardness testers 150x75x80cm	UN-STAND/965
			Seaworthy packing box for 950/960	PACK/100
	ISO / ASTM Verification		BRINELL direct and indirect verification/calibration & certification in compliance with ISO & ASTM, NADCAP. Includes direct force and indirect verification report (block readings), GR & R report, flat fee for selected common scales, per scale.	CALCEFRDW/1B
			ROCKWELL direct and indirect verification/calibration & certification in compliance with ISO & ASTM, NADCAP. Includes direct force and indirect verification report (block readings), GR & R report, flat fee for selected common scales, per scale.	CALCEFRDW/1R
	Cover		Machine cover 350x550x870mm	UN-COVER2

# ORDER DETAILS

## SOFTWARE

Additional Software	User level management	UN-LEVMAN	STANDARD
	Manual & automatic on-screen measurement	UN-MANM	STANDARD
	Advanced 3-axis communication protocol for robotic systems	UN-REMC	
Connectivity Plus	Blue Tooth connectivity	UN-BTADAPT	
	Utility software; Import test results in MS applications like Excel	UN-SW/905	
	USB to USB null modem cable 2.5M	BE-99-0025	
	Wireless system Keyboard & wireless mouse	UN-SKBSET	STANDARD
Upgrades	Upgrade Rockwell tester RS to RSB, Brinell scales, BIOS 1 system, Impressions Lite	UN-BPACK02	
	Upgrade Rockwell tester RS to RSB, Brinell scales, BIOS 2 system, Impressions lite	UN-BPACK03	





# ACCESSORIES

## OPTICAL SCANNERS

BPACK

(A)



UN-BIOS-1  
SA-12-0001

(B)



UN-BIOS-2  
SA-12-0002

## INDENTERS

(A)



Rockwell diamond indenter

(B)



1mm Carbide Ball Indenter Ø6.35mm

(C)



1/16" Carbide Ball Indenter

(D)



Macro Vickers Indenter Ø6.35mm

## MANUAL XY-STAGE

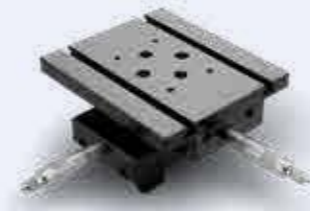

## TEST TABLES

(A)



ASV700-00-20  
UN-TESTTABLE/014

(B)



UN-TESTTABLE/015  
UN-TESTTABLE/016

## ANVILS

(A)



AS3000-19-04

(B)



UN-TESTTABLE/002

(C)



UN-ANVIL/010

(D)



UN-ANVIL/011

(E)



UN-VBLOCK404050

(F)



UN-CROSSBLOCK01

(G)



UN-ANVIL/005

(H)



UN-ANVIL/006

(I)



UN-ANVIL/040

(J)



UN-ANVIL/045

(K)



UN-ANVIL/050

(L)



UN-ANVIL/200

(M)



UN-CVANVIL680  
UN-CVANVIL50200

## FIXTURES AND VICES

(A)



UN-VICE/210

(B)



UN-VICE/215

(C)



UN-VICE/220

(D)



UN-VICE/230

(E)



UN-JOMFIX1

(F)



UN-JOMFIX3

## MACHINE STANDS

(A)



(B)



# SPECIFICATIONS

## HARDNESS SCALES

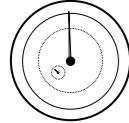
	<b>ROCKWELL</b> EN-ISO 6508, ASTM E-18 JIS Z 2245	Regular Rockwell scales; Pre Load 10kgf, Main Load 60kgf   100kgf   150kgf A   B   C   D   E   F   G   H   K   L   M   P   R   S   V Superficial Rockwell scales; Pre Load 3kgf, Main Load 15kgf   30kgf   45kgf 15N   30N   45N   15T   30T   45T   15W   30W   45W   15X   30X   45X   15Y   30Y   45Y
	<b>BRINELL</b> EN-ISO 6506, ASTM E10 JIS Z 2243	HBW1/1   HBW1/1.25   HBW1/2.5   HBW1/5   HBW1/10   HBW1/30 HBW 2.5/6.25   HBW 2.5/7.8125   HBW2.5/15.625   HBW2.5/31.25   HBW2.5/62.5   HBW2.5/187.5 HBW5/25   HBW5/31.25   HBW5/62.5   HBW5/125   HBW5/250 HBW10/100   HBW10/125   HBW10/250
	<b>HVD (HVT)</b>	HV5   HV10   HV20   HV30   HV50   HV100   HV120
	<b>HBD (HBT)</b>	HBT1/5kgf   HBT1/10kgf   HBT1/30kgf HBT2.5/6.25kgf   HBT2.5/15.625kgf   HBT2.5/31.25kgf   HBT2.5/62.5kgf   HBT2.5/187.5kgf HBT5/25kgf   HBT5/31.25kgf   HBT5/62.5kgf   HBT5/125kgf   HBT5/250kgf HBT10/100kgf   HBT10/125kgf   HBT10/250kgf
	<b>CARBON</b>	HR 2.5/7   HR 5/7   HR 5/15   HR 5/20   HR 5/40   HR 5/60   HR 5/100   HR 5/150   HR 10/20 HR 10/40   HR 10/60   HR 10/100   HR 10/150

## TEST FORCE

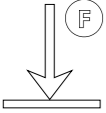
	<b>Force application</b>	Load cell, closed loop, force feedback
	<b>Test forces</b>	Rockwell scales : Preload 10kgf , main loads 60, 100, 150kgf Superficial Rockwell scales : Preload 3kgf , main loads 15, 30, 45kgf
	<b>Force range per model</b>	VERZUS 720RS 3kgf – 150kgf VERZUS 720RSB 1kgf – 250kgf
	<b>Test force tolerance</b>	< 0.5%
	<b>Dwell time settings</b>	Default 10 seconds, user defined 1 to 250 seconds

## SYSTEM

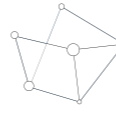
	<b>Electronic system</b>	Fully integrated Windows Controller, SSD hard disk, Windows 10 operated, IMPRESSIONS™ advanced workflow software, includes automatic measurement, keyboard & mouse
	<b>Screen(s)</b>	6.5" Industrial HD touch screen, embedded
	<b>Display resolution</b>	0.01 HR, HBW
	<b>Statistics</b>	Total tests, max, min, average, range, standard deviation, all in real time after each test test
	<b>Hardness conversion</b>	Rockwell, Vickers, Brinell, Leeb and Tensile, 5 scales simultaneously
	<b>Software</b>	IMPRESSIONS™ LT, work flow system & tester control
<b>Connectivity</b>	USB (3x), LAN RJ45, WLAN (Optional), Bluetooth (Optional)	

## GENERAL

	<b>Machine dimension</b>	320mm x 610mm x 860mm
	<b>Machine weight</b>	91kg
	<b>Power supply</b>	100VAC to 240VAC, 50/60Hz, single phase
	<b>Operating temperature</b>	10°C to 35°C, non-condensing
	<b>Power consumption</b>	100W
	<b>Noise</b>	< 70 db(A)
	<b>Humidity</b>	10% to 90%, non-condensing

# TECHNICAL DRAWINGS

All dimensions in these drawings are in mm, approximate. Working heights and or workpiece accommodation varies depending on the stages and stage accessories used.

Please contact our sales department for more details.

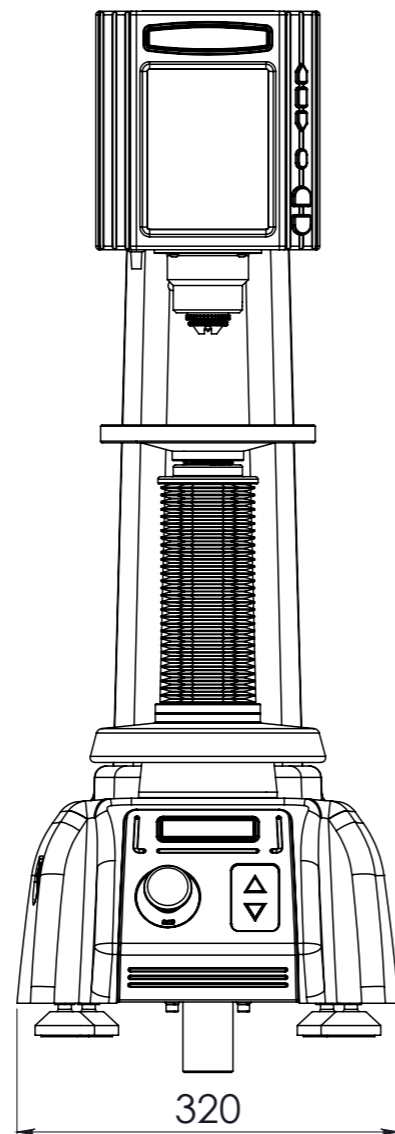
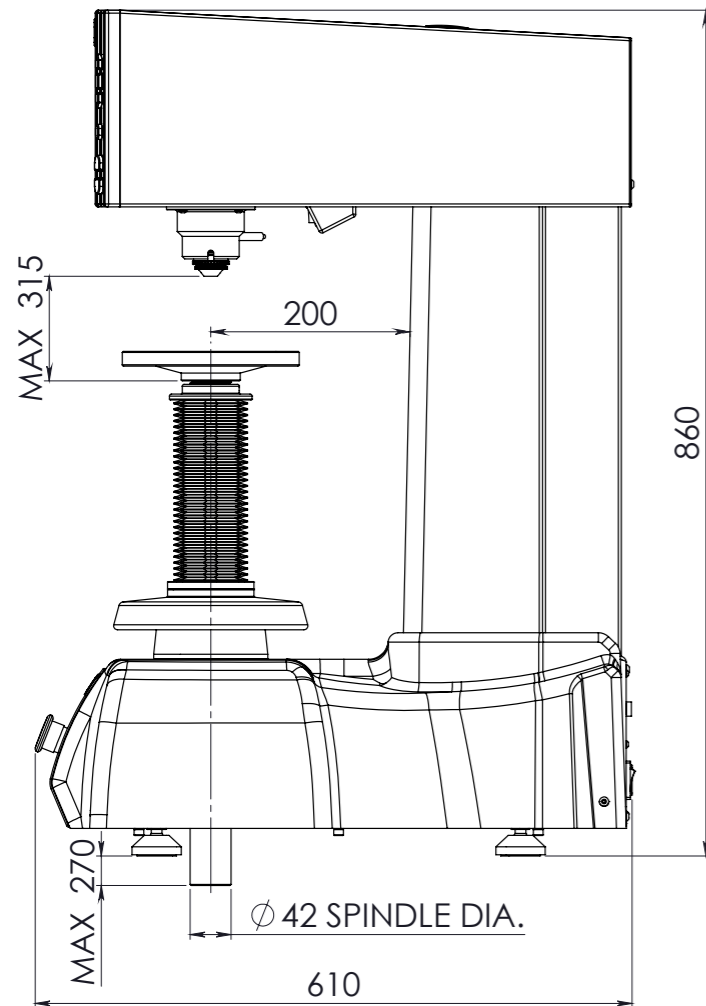

## OTHER MODELS IN THE ROCKWELL RANGE



### FENIX 200AR

Load applied from a dead weight force actuator Rockwell / Brinell hardness tester.

See brochure B18F200/XX



### FENIX 200ACL

Load Cell, closed loop, force feedback, test force application system Rockwell / Brinell hardness tester.

See brochure B18F200/XX



### FENIX 200DCL

Load Cell, closed loop, force feedback, test force application system Rockwell / Brinell hardness tester.

See brochure B18F200DCL/XX



### FENIX 300RS

Load Cell, closed loop, force feedback, test force application system Rockwell / Brinell hardness tester with I-TOUCH™ system.

See brochure B18F300/XX



### FENIX 300RS-IMP

Load Cell, closed loop, force feedback, test force application system Rockwell / Brinell hardness tester with IMPRESSIONS™ system.

See brochure B18F300/XX



### FENIX 300RS-XL

Load Cell, closed loop, force feedback, test force application system Rockwell / Brinell hardness tester.

Extra tall working height See brochure B18F300/XX



### HAWK 250RS/400RS

Load Cell, closed loop Rockwell/ Superficial Rockwell hardness tester, with direct depth measuring system, Graphic User Interface, 6.5" Full color touch screen  
See brochure B20HSERIES/XX



### HAWK 652RS-IMP

Load Cell, Closed loop Fully automatic Rockwell/ Superficial Rockwell hardness tester with dual motorized Z-Axis, Impressions software, 15" industrial capacitive touch screen.  
See brochure B20HSERIES/XX



### NEMESIS 9100RS

Load Cell, closed loop Rockwell/Superficial Rockwell/ Brinell hardness tester, with integrated PC, Windows 10, WiFi etc. full color touch screen.  
See brochure B18N9100/XX



### NEMESIS 9600RSB

Load Cell, closed loop Brinell, Rockwell, Superficial Rockwell Hardness tester With motorized Z-axis & BIOS Brinell Indent Optical Scanner  
See brochure B19N9600/XX



### NEMESIS 6100

Load Cell, Closed loop Fully automatic Rockwell/ Superficial Rockwell (Brinell) hardness tester with descending test head & fixed workpiece position. full color touch screen operation.  
See brochure B18N6100/XX



### NEMESIS 6200

Load Cell, Closed loop Fully automatic Rockwell/ Superficial Rockwell (Brinell) hardness tester with descending test head & fixed workpiece position, integrated PC, Windows 10, WiFi, full color 15" industrial capacitive touch screen.

Includes CNC motorized XY-stage, overview camera and advanced software (IMPRESSIONS) for automatic pattern testing and fixture recognition.  
See brochure B18N6200/XX



### NEXUS 8103RSB

Fully automatic, Load Cell, closed loop Brinell, Rockwell, Superficial Rockwell Hardness Testers with manual or motorized Z-Axis & Brinell Indent Optical Scanner.



### NEXUS 8103RSB-XLM

Fully automatic, Load Cell, closed loop Brinell, Rockwell, Superficial Rockwell Hardness Testers with manual or motorized Z-Axis & Brinell Indent Optical Scanner.

Distributor :

## **CORPORATE HEAD OFFICE**

### **INNOVATEST Europe BV**

**Manufacturing, Distribution & Service**

Borgharenweg 140  
6222 AA MAASTRICHT  
The Netherlands

Phone: +31 43 3520060

Fax: +31 43 3631168

[info@innovatest-europe.com](mailto:info@innovatest-europe.com)

[www.innovatest-europe.com](http://www.innovatest-europe.com)

### **INNOVATEST Deutschland GmbH Sales & Service**

Phone: +49 245 670 59 500  
[info@innovatest-deutschland.com](mailto:info@innovatest-deutschland.com)  
[www.innovatest-deutschland.com](http://www.innovatest-deutschland.com)

### **INNOVATEST Polska sp. z.o.o Sales & Service**

Phone: +48 697 099 826  
[info@innovatest-polska.pl](mailto:info@innovatest-polska.pl)  
[www.innovatest-polska.pl](http://www.innovatest-polska.pl)

### **INNOVATEST Shanghai Co., Ltd. Sales & Service**

Phone: +86 21 60906200  
[info@innovatest-shanghai.com](mailto:info@innovatest-shanghai.com)  
[www.innovatest-shanghai.com](http://www.innovatest-shanghai.com)

### **INNOVATEST Japan Co., Ltd. Sales & Service**

Phone: +81 3 3527 3092  
[info@innovatest-japan.com](mailto:info@innovatest-japan.com)  
[www.innovatest-japan.com](http://www.innovatest-japan.com)

### **INNOVATEST USA Company Sales & Service**

Phone: +1 267 317 4300  
[info@innovatest-usa.com](mailto:info@innovatest-usa.com)  
[www.innovatest-usa.com](http://www.innovatest-usa.com)

### **INNOVATEST South East Asia Sales & Service**

Phone: +65 6451 1123  
[info@innovatest-singapore.com](mailto:info@innovatest-singapore.com)  
[www.innovatest-singapore.com](http://www.innovatest-singapore.com)